

*199*  
**FOLDING TRAY**



This generously sized tray can be used separately or placed permanently on the folding stand. The classic design and rich walnut goes well with either contemporary or country furnishings.

1. Cut all stock to size according to the dimensions provided.
2. Glue up random width stock to make the tray bottom (C) slightly oversized. When the glue has dried, sand on both sides and trim the bottom to final size.
3. Miter the corners for connecting the back (A) and the tray sides (B). Cut 1/4"-wide x 1/2"-deep rabbets on the lower inside edges of the back and sides. Taper the inner face on each piece down to 3/8" thickness, beginning the taper at the top of the rabbet as shown.
4. Drill and cut out the handholes on the tray sides as shown.

5. Final sand the tray pieces, including the handholes. Assemble the tray using glue and 4d finishing nails at the corners, and glue and 2d finishing nails through the bottom into the sides. Pre-drill all nail holes for easier construction; set

the nails and fill the holes with matching wood putty.

6. Angle-cut the ends of the top rails (E) as shown.
7. Assemble the narrow inside frames first. Begin by locating and drilling 1/4"-diameter dowel holes 1" deep at the joints for the legs (D) and top and bottom rails (E, G).
8. On the outside of the narrow frame legs, drill 1/4"-diameter holes 1" deep exactly 17" from the bottom of the legs. This is the location of the pivot pins for folding the stand.
9. Glue the pivot pins in place, then assemble the narrow frame. Glue the dowel joints and clamp until dry. Check for squareness.
10. Drill 1/4"-diameter holes 1" deep exactly 17" from the bottom of the inside of the large frame legs. Assemble the top and bottom (F) rails and one side of the large frame.
11. Insert the small frame inside the large frame, lining up the pivot pins in the frame holes. Do not glue pins in the large frame legs.
12. Position and glue the remaining outside frame leg in place. Sand all stand parts at the joints and the surface.
13. Finish with clear polyurethane finish. When dry, you might want to tack or staple fabric strapping to the underside of the top rails so the frame opens up to 24" in width.

LIST OF MATERIALS	
(finished dimensions in inches)	
<b>A</b> Back	3/4 x 5 x 30
<b>B</b> Tray sides (2)	3/4 x 5 x 16-1/4
<b>C</b> Tray bottom	1/2 x 16 x 29
<b>D</b> Legs (4)	3/4 x 1-3/4 x 34-1/4
<b>E</b> Top rails (2)	3/4 x 1-3/4 x 16
<b>F</b> Bottom rail	3/4 x 1-3/4 x 10-1/2
<b>G</b> Bottom rail	3/4 x 1-3/4 x 7
Grooved dowel pivot pins	1/4 dia. x 2
Fabric strapping	1-1/2 x 2 x 32
2d finishing nails	
4d finishing nails	
Wood putty	
Wood glue	

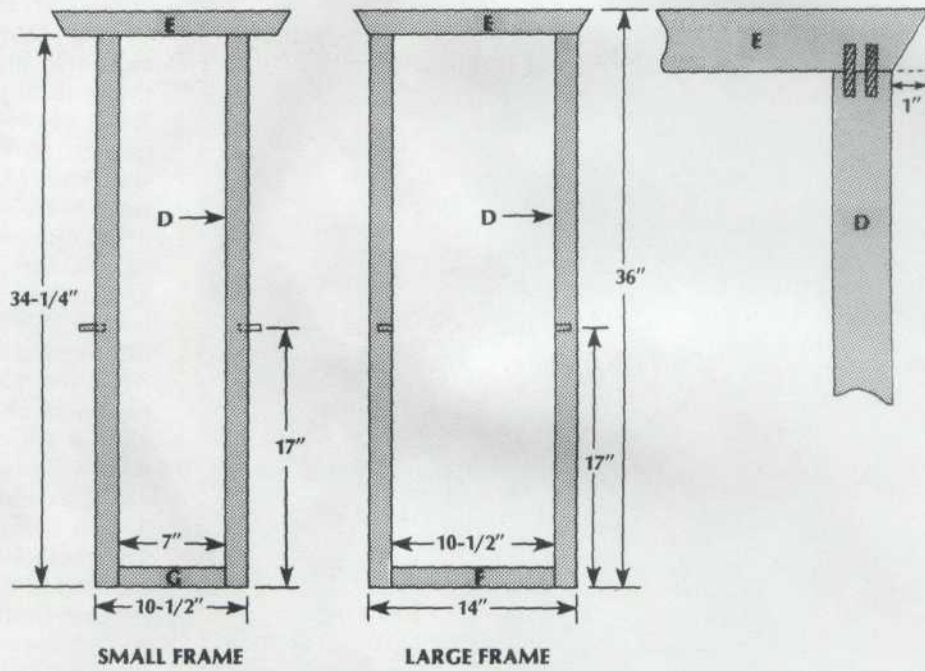
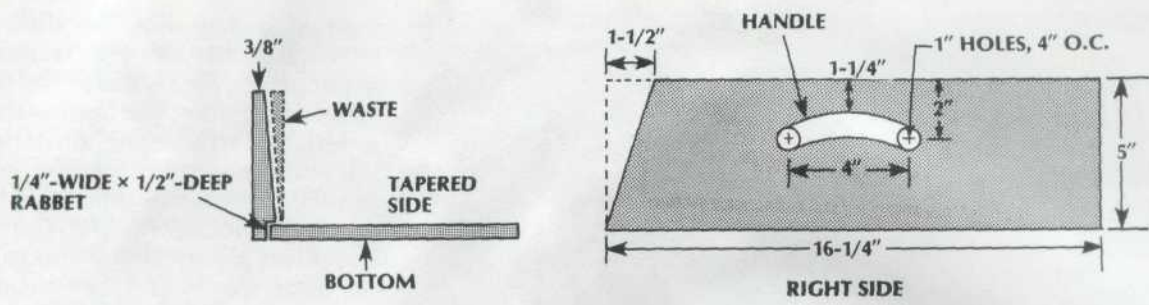

LEG ASSEMBLIES

