



Wow! I Made It.com

Gold Mirror

Want a great re-do for an old mirror? Frame it with ready-made trim and decorative squares. It's easy and inexpensive. And the frame can be adjusted to fit any size mirror. We spray-painted our mirror frame a bronze color to match our buffet.



Materials

- 12 linear feet of 1 x 4 pine
- 12 linear feet of 3" beaded molding
- 4 decorative squares, each measuring 4" square
- 1 mirror, 26-3/8" x 40-3/8" x 1/4" thick

Hardware

- 8 corrugated metal fasteners
- 30 $\frac{3}{4}$ brads
- 12 1 $\frac{1}{4}$ ' 3d finishing nails
- 2 screw eyes, $\frac{3}{8}$ " diameter
- Picture-hanging wire

Special tools and Techniques

- Chisel
- Router with rabbet cutter
- Rabbets

Cutting List

Code	Description	Qty.	Materials	Dimensions
A	Top/Bottom	2	1 x 4 pine	46" long
B	Side	2	1 x 4 pine	25" long
C	Decorative Square	4	Purchased	4" x 4"
D	Long Beaded Molding	2	3" wide	Cut to fit (39" long)
E	Short Beaded Molding	2	3" wide	Cut to fit (25" long)

Building the Frame

1. Cut two top/bottoms (A) from 1 x 4 pine, each measuring 46" long.
2. Cut two sides (B) from 1 x 4 pine, each measuring 25" long
3. Place the two top/bottoms (A) on a level surface, parallel to each other and 25 inches apart. Fit the two sides (B) between the two top/bottom (A) to form a 32 x 46-inch rectangle, as shown in *Figure 1*. Use two corrugated fasteners on each joint to hold the four pieces together. Place the inner fastener at least 1 inch from the inside of the frame.
4. Rout the inside edges of the assembled rectangle, $\frac{1}{4}$ " deep and $\frac{3}{4}$ " wide. Use a chisel to cut the corners of this rabbet square.
5. Place the mirror into the rabbet in the rectangular frame. The front surface of the mirror should be flush with the front of the rectangular frame.

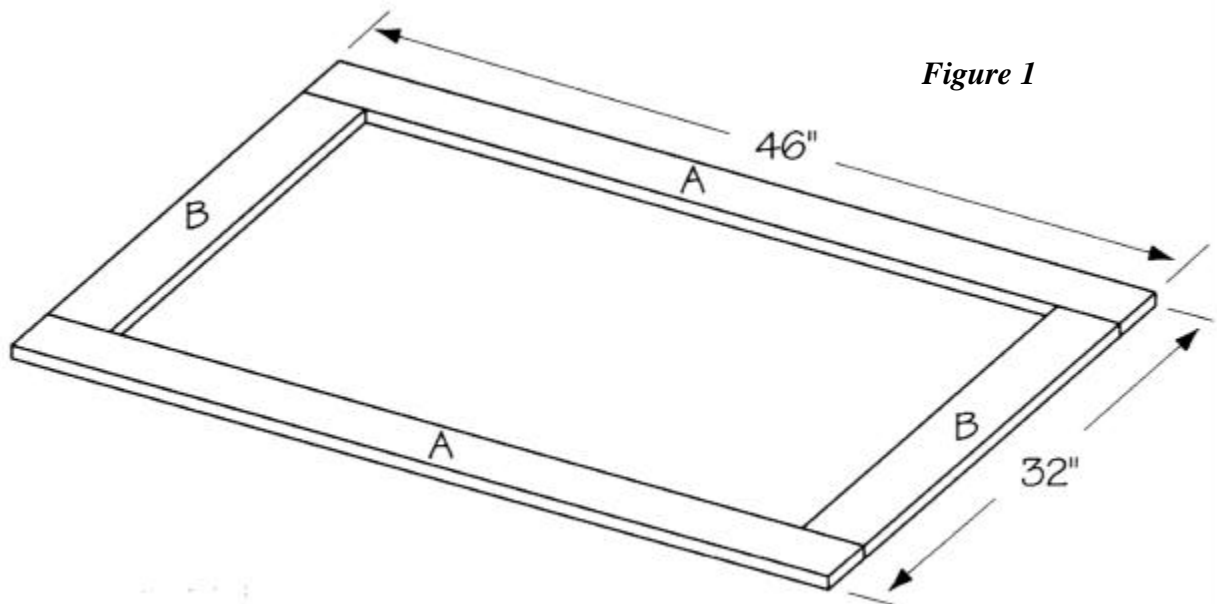

Figure 1

Adding the Trim

6. Refer to the project photograph and to *Figure 2* to place the trim on the mirror. Begin by placing the four decorative squares (C) at the four corners of the rectangular frame. They should extend over the outside of the rectangular frame by $\frac{1}{2}$ on each side. Use spring clamps or weights to hold the decorative squares (C) in place while you fit the long and short beaded moldings (D and E).
7. The beaded moldings (D and E) lie flush with the outside edge of the rectangular frame and fit between the decorative squares (C). Furthermore, the 3"-wide beaded moldings (D and E) must be centered widthwise on the 4-inch decorative squares (C). Measuring between the clamped decorative squares (C) cut the long beaded moldings (D) and the short beaded moldings (E) to fit. Lay the beaded moldings (D and E) in place and make sure that all the joints are snug.
8. Apply glue to the rectangular frame under each beaded molding (D and E), and nail through the beaded molding using $\frac{3}{4}$ brads spaced every 4 inches.
9. Remove the clamps or weights from the decorative squares (C). Glue and nail the four decorative squares (C) in place, using three 1-1/4" 3d finishing nails through each of the decorative squares (C).

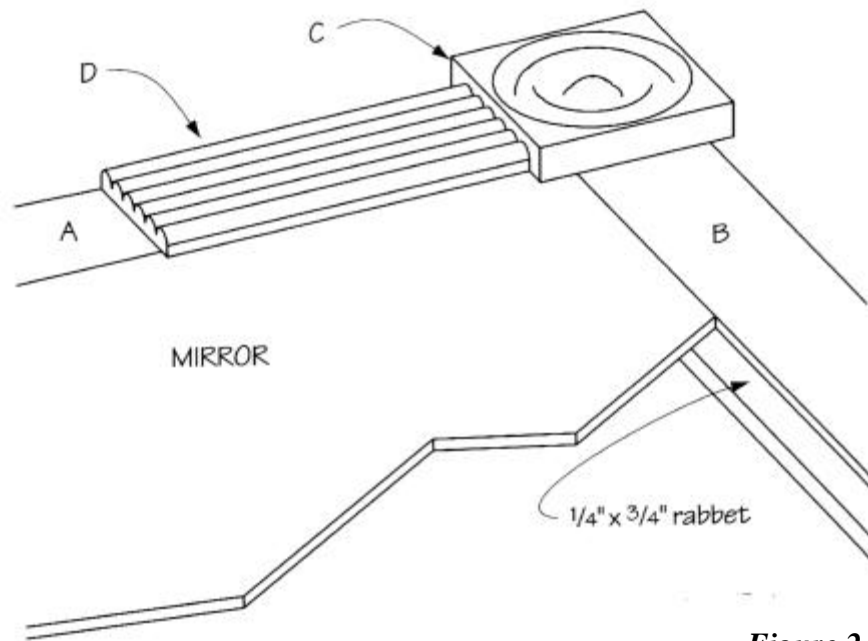

Figure 2

Finishing

10. Fill any screw holes or imperfections in the wood with wood filler.
11. Thoroughly sand all surfaces of the completed mirror.
12. Stain or paint the mirror the color of your choice. We chose a bronze paint to coordinate with our buffet.
13. Install one 3/8" screw eye in the back of each side (B) approximately 8 inches from the top of the completed frame. Connect the screw eyes with heavy-duty picture-hanging wire, following the manufacturer's recommendations.

**Create a Unified Whole! Coordinate Your Room with other
Projects from !**



This photograph contains seven projects available from : Kitchen Table, Entertainment Center, Tiled Coffee Table, Corner Display Cabinet, End Table, Mirror, and Buffet. Notice how everything is coordinated, and the rooms look unified because all of these pieces are designed in a similar scale, made of similar materials, and finished with similar techniques and colors.