

Name: _____

Exam Style Questions

Volume of a Cone



Corbettmaths

Ensure you have: Pencil, pen, ruler, protractor, pair of compasses and eraser

You may use tracing paper if needed

Guidance

1. Read each question carefully before you begin answering it.
2. Don't spend too long on one question.
3. Attempt every question.
4. Check your answers seem right.
5. Always show your workings

Revision for this topic

www.corbettmaths.com/contents

Video 359



1. A cone has base radius 5cm and perpendicular height 9cm.

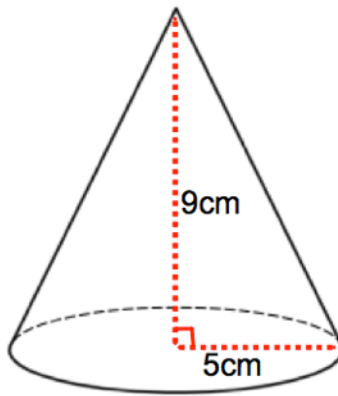

Work out the volume of the cone.

.....cm³
(3)

-
2. A cone has base diameter 18cm.
The height of the cone is 20cm.

Calculate the volume of the cone.
Leave your answer in terms of π

.....cm³
(3)

3. The volume of the cone shown below is 150 cm^3

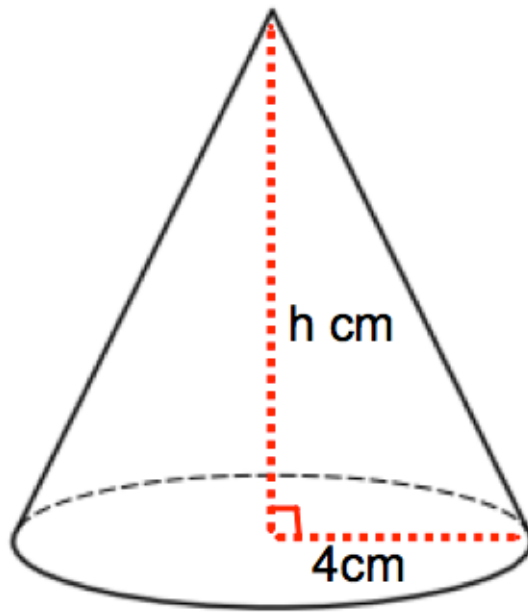

Calculate the height of the cone.
Give you answer to one decimal place.

.....cm
(3)

4. The volume of the cone shown below is 170 cm^3

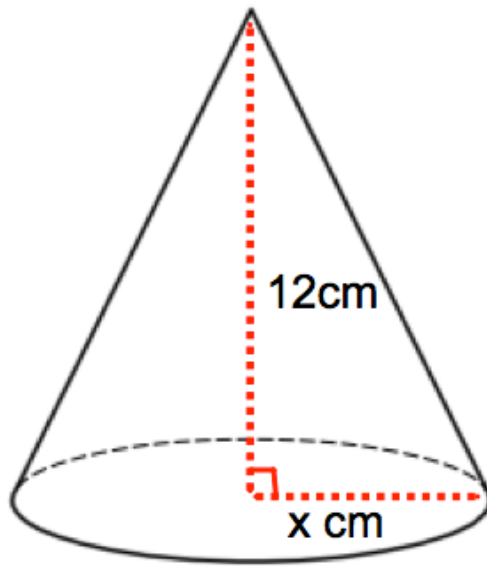

Calculate the radius of the base of the cone.
Give you answer to one decimal place.

.....cm
(3)

5. Shown is a cone and a triangular prism.

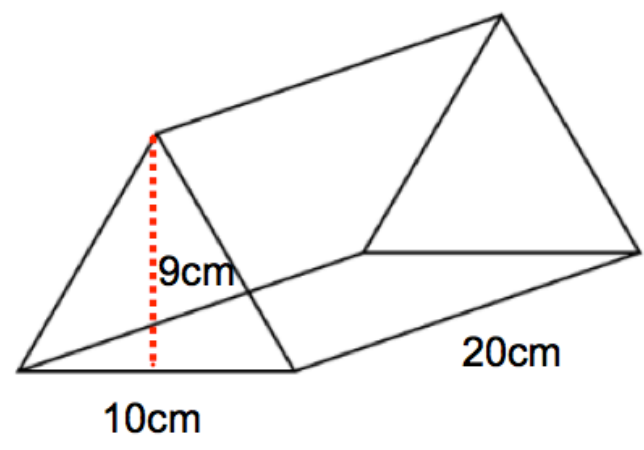
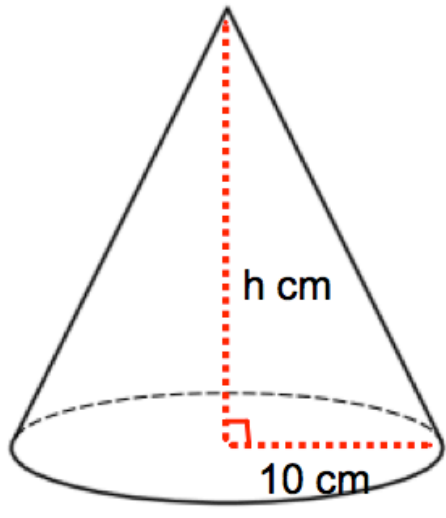

Both solids have the same volume.

Calculate the height of the cone.

.....cm
(3)

6. A large cone is cut into two parts, a smaller cone and a frustum of a cone.
The height of the large cone is 20cm.
The height of the smaller cone is 10cm.
The radius of the base of the large cone is 8cm.
The radius of the base of the smaller cone is 4cm.

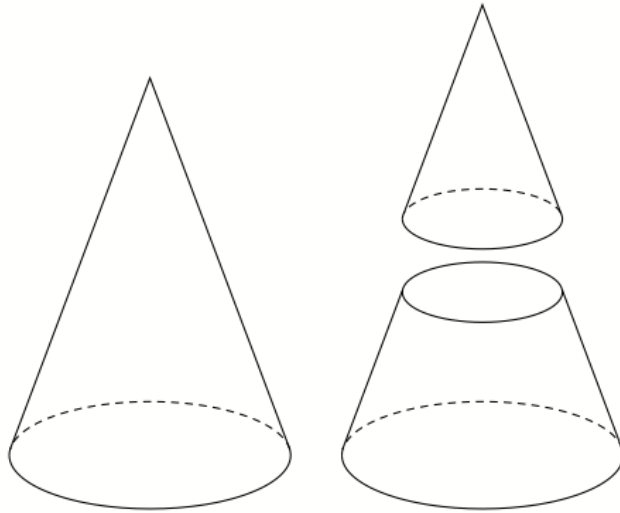

Work out the volume of the frustum.

.....cm³
(3)

7. A cone below has base radius 10cm and height h cm.
A smaller cone radius 4cm and height 6cm is cut from the top.
The frustum is shown below.

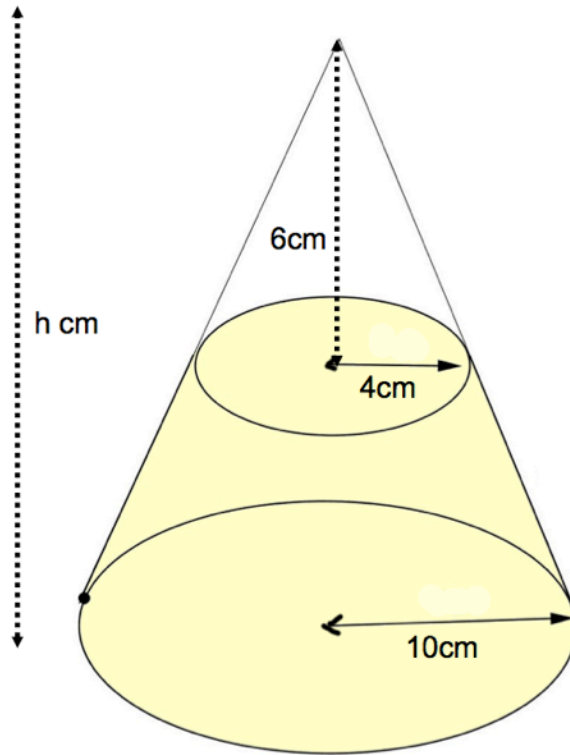

Calculate the volume of the frustum.

.....cm³
(5)

8. The diagram shows a solid made up of a cone and a hemisphere.

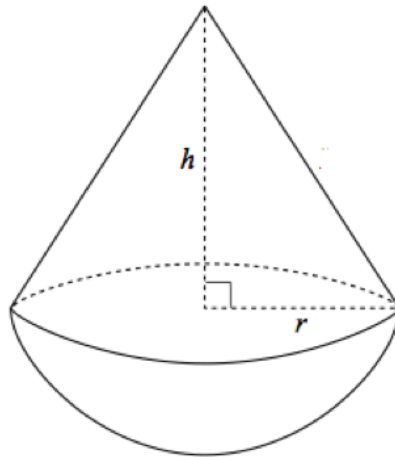

The radius of the cone is 5cm.
The height of the cone is 8cm.
The volume of a hemisphere is $\frac{2}{3}\pi r^3$

Calculate the volume of the solid.

.....cm³
(3)

9. The diagram shows a cone and a hemisphere.

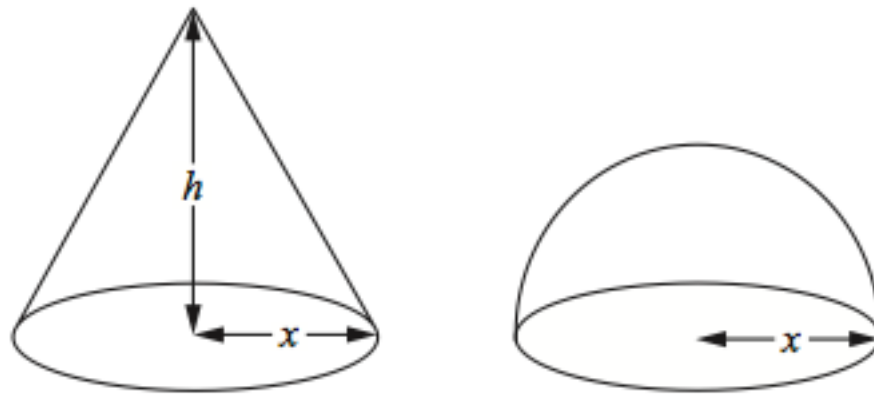

The hemisphere has base radius x cm.

The cone has base radius x cm and perpendicular height h cm.

The volume of the cone is equal to the volume of the hemisphere.

The volume of a hemisphere is $\frac{2}{3}\pi r^3$

Find an expression for h in terms of x .

$h = \dots\dots\dots$
(4)